

FSK324 Test 1

Solid State Physics

August 2013

Time: 120 minutes

Total marks: [80]

Section A - Crystal structure:

1. Determine the indices of S_1 and S_2 shown in Fig. 1. [6]

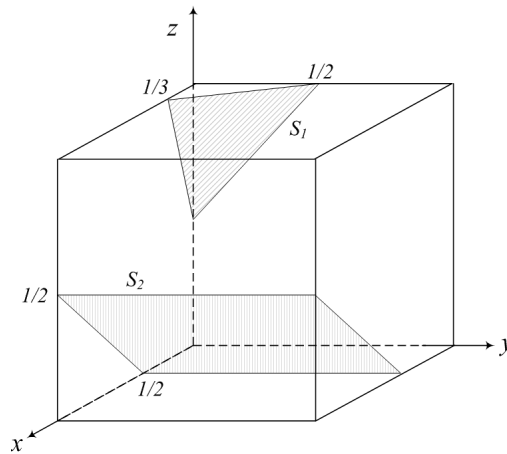

Figure 1: Unit cell for problem 1.

2. Sketch the following Miller indices:
- i.) $(0 \bar{2} 0)$ [2]
 - ii.) $[0 \bar{2} 0]$ [2]
 - iii.) Hence show that the above indicate perpendicular directions or planes. [4]
3. Alpha-iron (α -Fe) is BCC with lattice parameter 0.286 nm, density 7.9 g/cm³ and atomic mass 56. Determine the lattice parameter of gamma-iron (γ -Fe) that is FCC (see also Figure 3). [6]
4. Determine the indices of \bar{r} , \bar{s} , \bar{t} and \bar{u} shown in Fig.2. [8]
5. Consider the orthorhombic lattice: $a=1.25\text{\AA}$, $b=2.4\text{\AA}$ and $c=2.0\text{\AA}$.
- i.) Draw a labeled diagram of the real lattice [2]

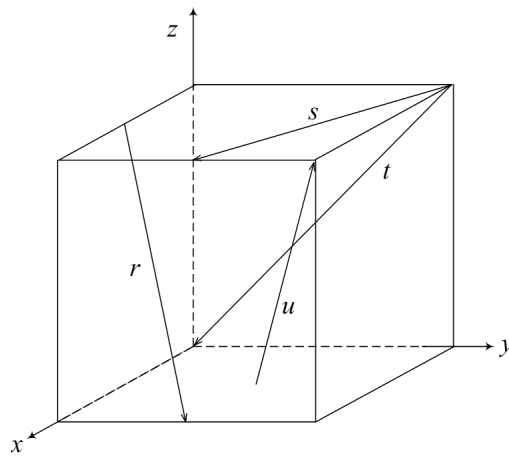

Figure 2: Unit cell for problem 4.

- ii.) Determine the volume ratio of the unit cell in real space to reciprocal space [4]
6. A cubic crystal has a lattice parameter of 2.42\AA . Determine the Bragg angle for the reflections (100), (200) and (211) given an x-ray energy of 8056 eV. [6]

Section B - Diffraction and the reciprocal lattice

Answer all questions in this section

7. The symmetry rules for some highly symmetrical structures are shown in Table 1.

Table 1: Some basic rules for some structures.

Lattice type	Rule for reflection
Primitive	None
Body-centered	$h+k+l=2n$
Face-centered	h, k, l either all odd or all even
Side-centered	$h+k=2n$
Rhombohedral	$(-h+k+l)=3n$ or $(h-k+l)=3n$

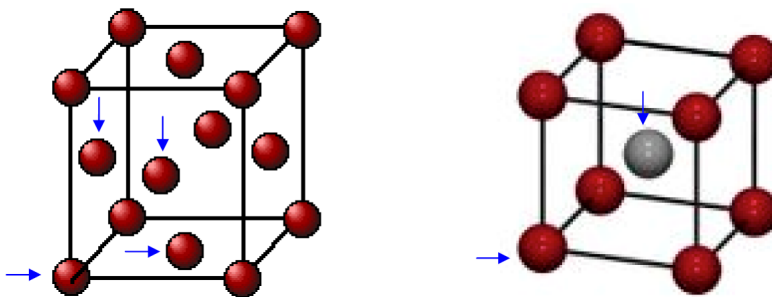

Figure 3: Two different unit cells of iron.

Determine the possible reflections for each iron unit cell shown in Figure 3. *Hint:* Considering only the highlighted (arrows) atoms, first write the fractional coordinates, determine the structure factor and then the possible reflections. [20]

8. Fig. 4 shows the first four peaks of the x-ray diffraction pattern for FCC copper using a x-ray of 0.1542nm wavelength. Determine

- i.) the h , k and l indices for each of these peaks. [6]
- ii.) the inter-planar spacing for each of the peaks. [6]
- iii.) the atomic radius for Cu using each peak. [8]

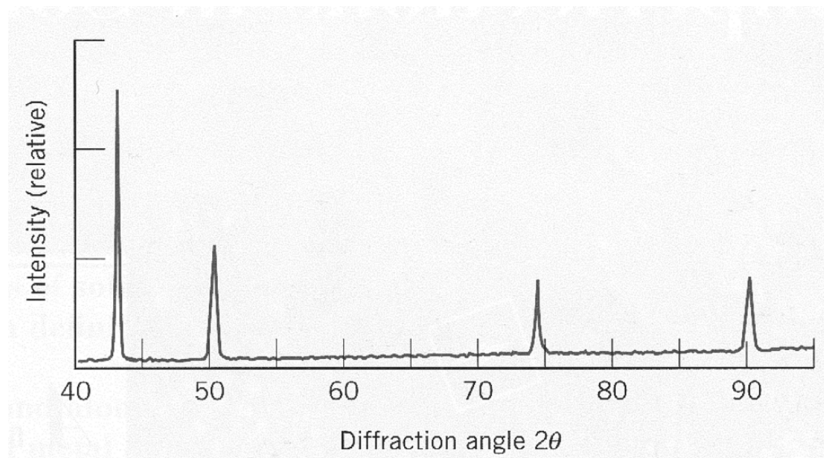

Figure 4: Unit cell for problem 8.

Some constants

Planck's constant	$h = 6.626 \times 10^{-34} \text{ J}\cdot\text{s}$, and $\hbar = h/2\pi$
Avogadro's constant	$6.022 \times 10^{23} \text{ mol}^{-1}$
Electronic charge	$e = 1.6022 \times 10^{-19} \text{ C}$
Electron mass	$m_e = 9.109 \times 10^{-31} \text{ kg}$
Neutron mass	$m_n = 1.675 \times 10^{-27} \text{ kg}$
Boltzmann's constant	$k_B = 1.38 \times 10^{-23} \text{ J/K}$